

TECHNICAL DATA SHEET FOR P8M PROVER/HOLDING CABINET

Full Size Manual / Electric

STANDARD FEATURES

- Dual function Prover and Holding Cabinet
- Designed for individual use or system installed with Turbofan 32D Convection Ovens
- 8 18" x 26" / 460 x 660 full size sheet pan capacity
- 16 18" x 13" / 460 x 330 half size sheet pan capacity
- 8 600 x 400 tray capacity (optional kit)
- 76mm tray spacing
- Compact 735mm width
- 13A plug-in cordset fitted
- Full double skin construction
- Auto water fill system with optional integrated water filter kit
- Continuous door seal
- Side hinged door (standard LH hinge). Optional RH hinge (field convertible)
- Off / Prove / Hold mode selection
- Low velocity circulation fan system
- Mechanical thermostat
- Humidity level control
- Dual halogen cabinet interior lamps
- Cabinet temperature display thermometer
- 4 dia. 76mm castors with 2 front castors dual wheel and swivel lock, 2 rigid rear castors
- 100% recyclable packaging

ACCESSORIES

- 600 x 400 tray racking kit
- Optional 3M Cuno water filter kit complete with cartridge and connection fittings
- Installs in pre-fitted rear housing of cabinet for flush rear installation



P8M

Unit shall be a Blue Seal electrically heated Turbofan Prover and Holding Cabinet. The prover and holding cabinet shall have double skin construction with stainless steel interior and exterior sides, front and top. Door shall be side hinged and field reversible. Unit shall have capacity for up to 16 half size sheet pans or 8 full size sheet pans. A single speed fan shall gently and evenly circulate air around the cabinet. Cabinet shall be controlled by a mechanical thermostat and humidity via a control of the water tank. A thermometer shall indicate the cabinet temperature. Prover and holding cabinet shall be mounted on castors, with two rigid castors at rear and two swivel castors dual swivel and wheel lock and front. Prover and Holding cabinet shall operate independently or in combination with Blue Seal Turbofan model E32D4 or G32D4 Convection Ovens. Prover and Holding Cabinets shall be fitted with 13A cordsets. Unit shall be supplied in 100% recyclable shipping packaging.

P8M Full Size Manual / Electric Prover/Holding Cabinet

CONSTRUCTION

304 stainless steel interior cabinet
 Stainless steel front, sides and top exterior
 Stainless steel interior side racks
 Stainless steel frame side hinged door
 5mm thick door glass
 Stainless steel control panel
 Aluminised coated steel base and rear panels

CONTROLS

Off / Prove / Holding mode selector switch.
 Mechanical thermostat 20-85°C
 Air heating ON control panel indicator
 Humidity level control
 Humidity tank ON control panel indicator
 Cabinet temperature thermometer
 Auto-fill water system standard

CLEANING

Stainless steel top and side exterior panels
 Stainless steel interior chamber
 Easy access to all interior surfaces
 Fully removable stainless steel rack support
 Removable humidity water tank (no tools)

SPECIFICATIONS

Electrical Requirements
 230-240V, 50Hz, 1P+N+E, 1.5kW, 6.3A
 13A cordset fitted

Water Requirements (optional)

Cold water connection ¾" BSP male
 80psi maximum inlet pressure / 20psi minimum inlet pressure

External Dimensions

Width 735mm
 Height 914mm including dia. 76mm castors
 Depth 810mm

Prover Internal Dimensions

Width 65mm
 Height 730mm
 Depth 700mm
 Volume 0.24m³

Nett Weight

77.5kg

Packing Data

95.3kg
 0.76m³
 Width 760mm
 Height 1080mm
 Depth 925mm

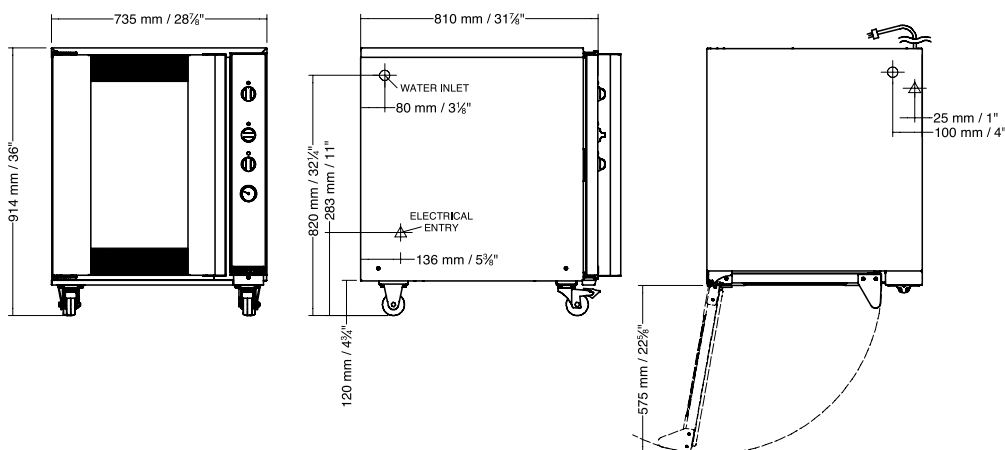

BLUE SEAL

www.blue-seal.co.uk
 www.bluesealequipment.com
 www.turbofanoven.com

United Kingdom Blue Seal Limited

Unit 67
 Gravelly Business Park
 Gravelly
 Birmingham B24 8TQ
 England
 Telephone 0121-327 5575
 Facsimile 0121-327 9711
 sales@blue-seal.co.uk
 www.blue-seal.co.uk
 www.bluesealequipment.com

Australia Moffat Pty Limited

740 Springvale Road
 Mulgrave, Victoria 3170
 Australia
 Telephone 03-9518 3888
 Facsimile 03-9518 3833
 vsales@moffat.com.au
 www.moffat.com.au

New Zealand Moffat Limited

16 Osborne Street
 PO Box 10-001
 Christchurch 8011
 Telephone 03-389 1007
 Facsimile 03-389 1276
 sales@moffat.co.nz



ISO9001
 Quality
 Management
 Standard

Designed and manufactured by
MOFFAT

ISO9001
 All Turbofan products are designed and manufactured by Moffat using the internationally recognised ISO9001 quality management system, covering design, manufacture and final inspection, ensuring consistent high quality at all times.

In line with policy to continually develop and improve its products, Moffat Limited reserves the right to change specifications and design without notice.



© Copyright Moffat Ltd
 Moffat 6.10

